

AD-A3A8-P4A	SMA Plug to SMA Jack 4 Hole Flange 18GHz VSWR 1.2	50Ω
-------------	--	-----

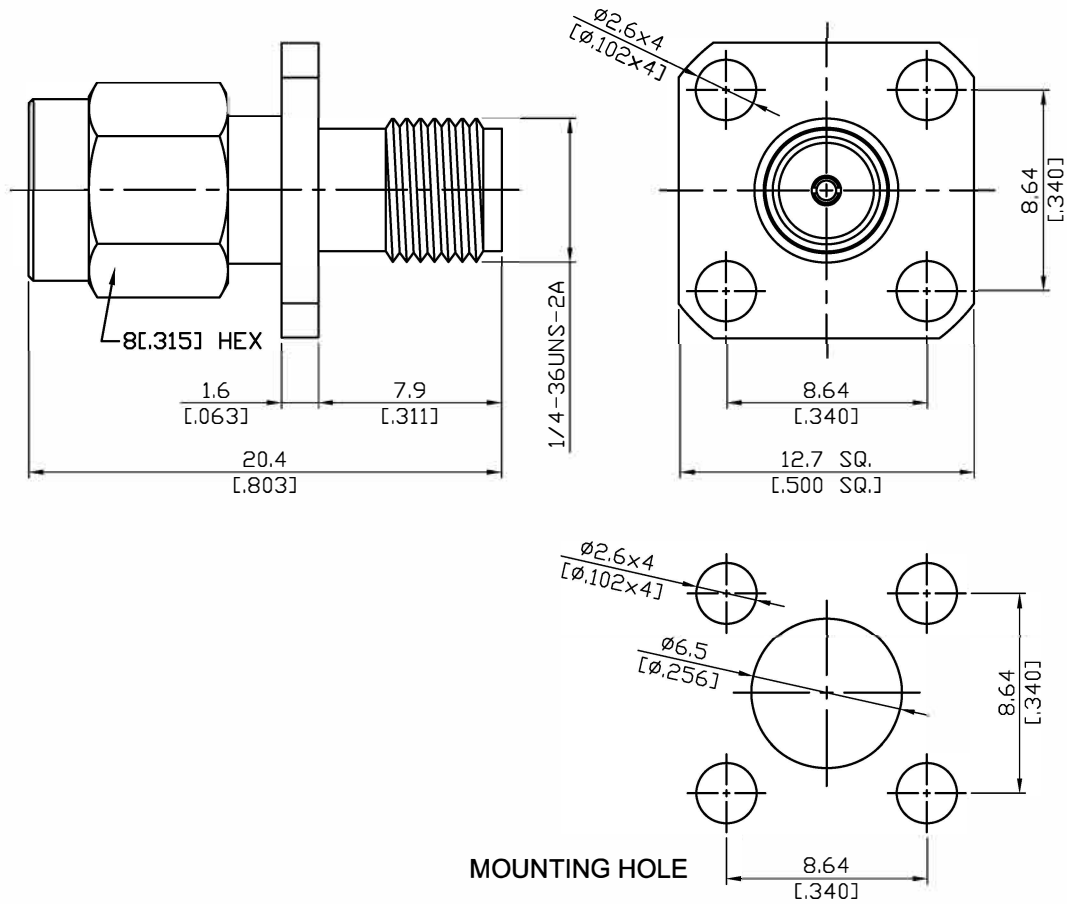

Parts	Material	Plating ( Micro-inch )
Contact Pin	Beryllium Copper	Gold 4 Over Nickel-Phosphorus Alloy 80 Over Copper 20
Retainer Ring	Beryllium Copper	Tin-Zinc-Copper-Alloy 100 Over Copper 50
Gasket	Silicone	
Insulator	Teflon	
Body	Brass	Gold 4 Over Nickel-Phosphorus Alloy 80 Over Copper 20
Coupling Nut	Brass	Gold 4 Over Nickel-Phosphorus Alloy 80 Over Copper 20

--	--

This part number complies with RoHS.

Notice: JYEBAO reserves the right to make modifications deemed appropriate.

AD-A3A8-P4A	SMA Plug to SMA Jack 4 Hole Flange 18GHz VSWR 1.2																
<table border="0"> <tr> <td colspan="2" data-bbox="129 342 531 392"><b>Interface</b></td> </tr> <tr> <td data-bbox="129 398 774 436">Standard</td> <td data-bbox="774 398 1481 436">MIL-STD-348B</td> </tr> <tr> <td data-bbox="129 443 774 481">Mechanically compatible with</td> <td data-bbox="774 443 1481 481">2.92 &amp; 3.5</td> </tr> </table>		<b>Interface</b>		Standard	MIL-STD-348B	Mechanically compatible with	2.92 & 3.5										
<b>Interface</b>																	
Standard	MIL-STD-348B																
Mechanically compatible with	2.92 & 3.5																
<table border="0"> <tr> <td colspan="2" data-bbox="129 602 531 651"><b>Electrical Data</b></td> </tr> <tr> <td data-bbox="129 658 774 696">Impedance</td> <td data-bbox="774 658 1481 696">50Ω</td> </tr> <tr> <td data-bbox="129 703 774 741">Frequency Range</td> <td data-bbox="774 703 1481 741">DC To 18GHz</td> </tr> <tr> <td data-bbox="129 748 774 786">VSWR</td> <td data-bbox="774 748 1481 786">≤ 1.2 (DC To 18GHz)</td> </tr> <tr> <td data-bbox="129 792 774 831">Insertion Loss</td> <td data-bbox="774 792 1481 831">≤ 0.04 x √f(GHz) dB</td> </tr> <tr> <td data-bbox="129 837 774 875">Insulation Resistance</td> <td data-bbox="774 837 1481 875">≥ 5000MΩ</td> </tr> <tr> <td data-bbox="129 882 774 920">Dielectric Withstanding Voltage (at sea level)</td> <td data-bbox="774 882 1481 920">1500 V rms</td> </tr> <tr> <td data-bbox="129 927 774 965">Working Voltage (at sea level)</td> <td data-bbox="774 927 1481 965">500 V rms</td> </tr> </table>		<b>Electrical Data</b>		Impedance	50Ω	Frequency Range	DC To 18GHz	VSWR	≤ 1.2 (DC To 18GHz)	Insertion Loss	≤ 0.04 x √f(GHz) dB	Insulation Resistance	≥ 5000MΩ	Dielectric Withstanding Voltage (at sea level)	1500 V rms	Working Voltage (at sea level)	500 V rms
<b>Electrical Data</b>																	
Impedance	50Ω																
Frequency Range	DC To 18GHz																
VSWR	≤ 1.2 (DC To 18GHz)																
Insertion Loss	≤ 0.04 x √f(GHz) dB																
Insulation Resistance	≥ 5000MΩ																
Dielectric Withstanding Voltage (at sea level)	1500 V rms																
Working Voltage (at sea level)	500 V rms																
<table border="0"> <tr> <td colspan="2" data-bbox="129 1099 531 1149"><b>Mechanical Data</b></td> </tr> <tr> <td data-bbox="129 1155 774 1193">Recommended Coupling Nut Torque</td> <td data-bbox="774 1155 1481 1193">4 in-lbs</td> </tr> <tr> <td data-bbox="129 1200 774 1238">Coupling Proof Torque</td> <td data-bbox="774 1200 1481 1238">5.3 in-lbs</td> </tr> <tr> <td data-bbox="129 1245 774 1283">Coupling Nut Retention Force</td> <td data-bbox="774 1245 1481 1283">≥ 60.7 lbs</td> </tr> <tr> <td data-bbox="129 1290 774 1328">Contact Captivation-axial</td> <td data-bbox="774 1290 1481 1328">≥ 6.1 lbs</td> </tr> <tr> <td data-bbox="129 1335 774 1373">Durability (mating)</td> <td data-bbox="774 1335 1481 1373">≥ 100</td> </tr> </table>		<b>Mechanical Data</b>		Recommended Coupling Nut Torque	4 in-lbs	Coupling Proof Torque	5.3 in-lbs	Coupling Nut Retention Force	≥ 60.7 lbs	Contact Captivation-axial	≥ 6.1 lbs	Durability (mating)	≥ 100				
<b>Mechanical Data</b>																	
Recommended Coupling Nut Torque	4 in-lbs																
Coupling Proof Torque	5.3 in-lbs																
Coupling Nut Retention Force	≥ 60.7 lbs																
Contact Captivation-axial	≥ 6.1 lbs																
Durability (mating)	≥ 100																
<table border="0"> <tr> <td colspan="2" data-bbox="129 1503 531 1552"><b>Environmental Data</b></td> </tr> <tr> <td data-bbox="129 1559 774 1597">Temperature Range</td> <td data-bbox="774 1559 1481 1597">-65°C to +165°C</td> </tr> <tr> <td data-bbox="129 1603 774 1641">Thermal Shock</td> <td data-bbox="774 1603 1481 1641">MIL-STD-202, Method 107, Condition B</td> </tr> <tr> <td data-bbox="129 1648 774 1686">Moisture Resistance</td> <td data-bbox="774 1648 1481 1686">MIL-STD-202, Method 206</td> </tr> <tr> <td data-bbox="129 1693 774 1731">Corrosion</td> <td data-bbox="774 1693 1481 1731">MIL-STD-202, Method 101, Condition B</td> </tr> <tr> <td data-bbox="129 1738 774 1776">RoHS</td> <td data-bbox="774 1738 1481 1776">Compliant</td> </tr> </table>		<b>Environmental Data</b>		Temperature Range	-65°C to +165°C	Thermal Shock	MIL-STD-202, Method 107, Condition B	Moisture Resistance	MIL-STD-202, Method 206	Corrosion	MIL-STD-202, Method 101, Condition B	RoHS	Compliant				
<b>Environmental Data</b>																	
Temperature Range	-65°C to +165°C																
Thermal Shock	MIL-STD-202, Method 107, Condition B																
Moisture Resistance	MIL-STD-202, Method 206																
Corrosion	MIL-STD-202, Method 101, Condition B																
RoHS	Compliant																

# AD-A3A8-P4A

